



Pollution by 2-Stroke Engines

By
Engr. Aminu Jalal
National Automotive Council

At

The Nigerian Conference on Clean Air, Clean Fuels and
Vehicles,
Abuja, 2-3 May 2006



Introduction to the 2-Stroke Engine

- The 2-stroke cycle of an internal combustion engine has only two strokes (linear movements of the piston) instead of four, although the same four operations (intake, compression, power, exhaust) still occur. It is usually found in low power applications like lawn mowers, mopeds, small outboard motors, etc.
- Its advantages over 4-stroke:
 - They do not have valves, which simplifies their construction and lowers their weight.
 - They fire once every revolution, while 4-stroke engine fires once every other revolution. This gives them better power to weight ratio.
 - They can work in any orientation, which can be important in handheld devices (like chainsaws) as there is no oil reservoir dependant upon gravity.



Introduction to the 2-Stroke Engine Contd.

- However, the 2-stroke engine has significant disadvantages compared to 4-stroke engines, that will be better understood if we look at how it operates
- 2-Stroke Engine Operation
 - A simple 2-stroke contains a piston whose face is shaped, an exhaust port on one side of the cylinder and an intake port on the other side. The downward movement of the piston first uncovers the exhaust port, allowing most of the Exhaust to be expelled and then uncovers the inlet port through which the air-fuel mixture is let into the cylinder. The piston then moves upwards, compressing the mixture which is ignited by the spark plug, driving the piston down.

©2001 HowStuffWorks

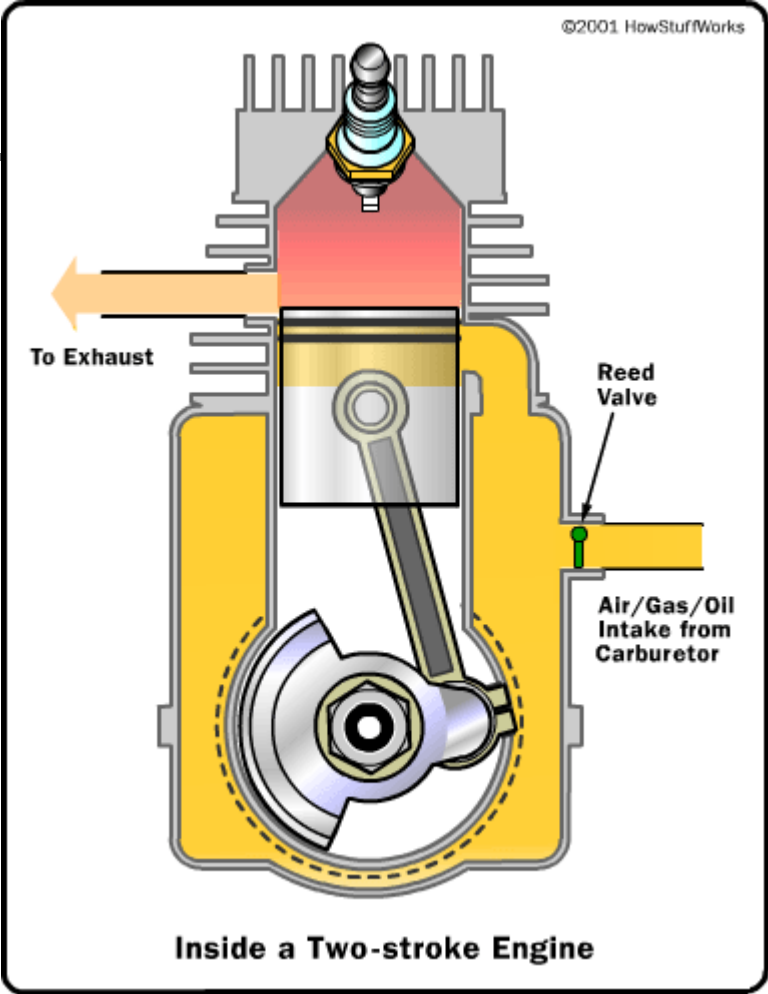

To Exhaust

Reed Valve

Air/Gas/Oil Intake from Carburetor

Inside a Two-stroke Engine

©2001 HowStuffWorks

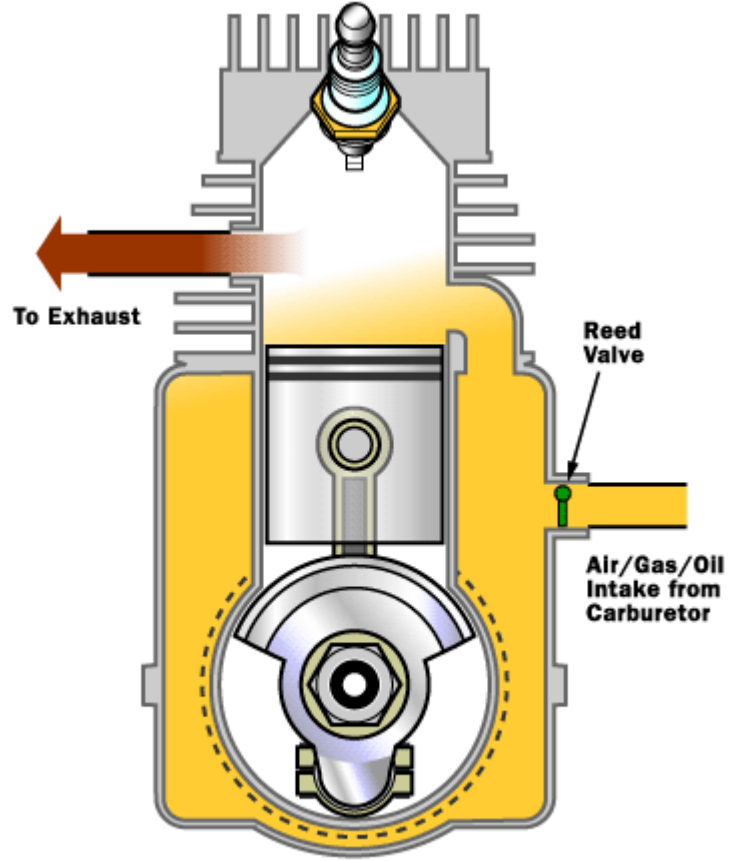

To Exhaust

Reed Valve

Air/Gas/Oil Intake from Carburetor

Fuel-intake position of a two-stroke engine

©2001 HowStuffWorks

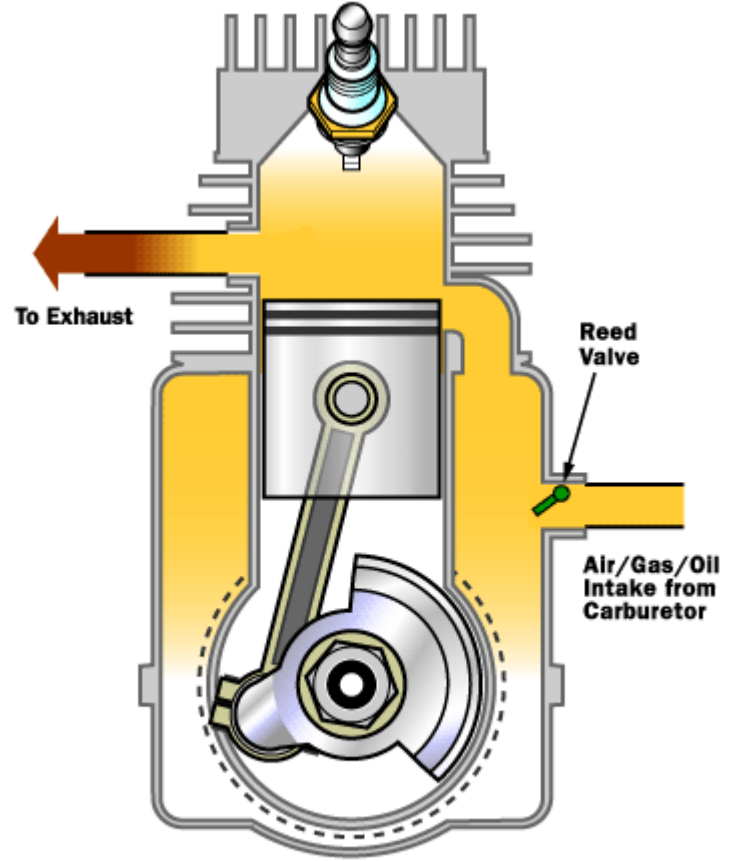

Compression action of a two-stroke engine



Introduction to the 2-Stroke Engine Contd.

■ Disadvantages 2-Stroke Engines

- There is no dedicated lubrication system, the lubricant is mixed with fuel. 2-stroke engines therefore do not last as long as 4-stroke as their parts wear out faster.
- 2-stroke engines do not use fuel efficiently. Each time a new charge of air-fuel is loaded into the combusting chamber, a part of it leaks out through the exhaust port.
- The burning of lubricating oil and the exhaust of un-burnt fuel makes them more polluting than a 4-stroke engine of similar power.
- These disadvantages limits 2-stroke engines to be used only in applications where the motor is not used very often and high power to weight ration is important.

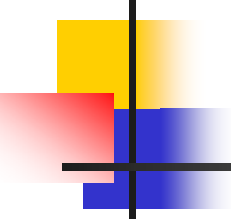

Emissions by 2-stroke Engines

- The 2-stroke engine emits significant amount of particulate matter (PM), un-burnt hydrocarbons (HC), Carbon Monoxide (CO) and Nitrogen Oxides (NO_x). CO and NO_x emissions by 2-stroke engines is much lower compared to 4-stroke engines.
 - PM: Lubricating oil is less combustible than gasoline, some of the oil that is mixed with gasoline will survive to be emitted in the exhaust. This is further worsened locally as engine oil mixed is up to twice the manufacturers recommendations (4%). It is estimated that particulate emissions from a single 2-stroke motorcycle is comparable to those from a diesel truck or bus. PM, particularly the finer ones, are associated with respiratory problems.

Emissions by 2-stroke Engines

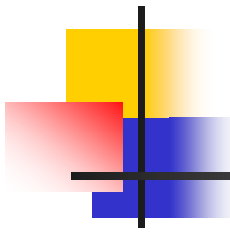

- HC emissions result from the elements of the air-fuel mixture that fail to burn in the engine due to leakage through the exhaust port, weak compressing causing partial combustion and misfiring (About 30% of the fuel comes out of the exhaust un-burnt in 2-stroke engines).
- Some gasoline components like benzene are carcinogens, while others combine with NO_x to form ozone. Ozone affects the respiratory system, reduces visibility, damages vegetation and contributes to photochemical smog.
- Two stroke engines have much higher emissions of PM and HC than 4-stroke engines of similar power and size. In the USA, motorcycle manufacturers switched to making 4-stroke engines in 1978, in response to the adoption of strict emission standards. Other European countries and Japan followed suit.



Reducing Emissions by 2-stroke Engines

- In the last decade, motorcycles have become important as a means of transport in Nigeria. Estimated annual supply of new motorcycles into Nigeria is one million units annually. Almost all of these have 2-stroke engines.
- Emissions from 2-stroke engines can be reduced by rigorous inspection and maintenance programmes and used of lubricating oil of correct quality and quantity. But the best option is to ban the use of 2-stroke engines in new motorcycles in favour of 4-stroke engines. 4-stroke engines may be slightly more expensive, but are cheaper to run as they are more fuel efficient and last longer.



Reduction Emissions by 2-stroke Engines

- In view of the foregoing, the following measures are recommended to reduce emissions from 2-stroke engines:
 - Engine oil for 2-stroke engines is unavailable, in Abuja at least. The oil companies should therefore be asked to produce 2-stroke engine oils. Motorcycle users should be educated by the FRSC and the States' Directorates of Motor Transport Administration on the correct engine maintenance and engine oil use.
 - The Nigerian government should ban the production and import of motorcycles with 2-stroke engines from 1 October 2006.

- 
-
- Thank you very much for your attention!