

Regional Workshop

“Towards fuel compliance”

12 / 13 February 2009, Ohrid



THE REGIONAL ENVIRONMENTAL CENTER
for Central and Eastern Europe

INTRODUCTION

- OKTA Refinery is the only Fuel producer in Macedonia for almost 30 years;
- OKTA Refinery is fully directed to reach Fuels and Environment Requirements of the EU and almost all investments in last period are focused to reach that goal;
- OKTA Accredited Laboratory is one of the guaranties of Fuel quality produced in OKTA



OKTA REFINERY HISTORY

- The Refinery was founded in 1978 and Operation started in 1982
- Refinery is Simple Hydroskimming of Russian technology;
- The design capacity was planned to cover the markets of Macedonia, Kosovo and South Serbia, 2.5 M tons/yr, but maximum reached capacity is 1,3 M tons/yr in 1988
- EL.P.ET. – Balkanike, member of Hellenic Petroleum group became a Strategic Investor with 54% of the shares in property in 1999
- Investments for Refinery Modernization, improving Fuel quality and Environmental projects started in 2000



COMPANY OWNERSHIP

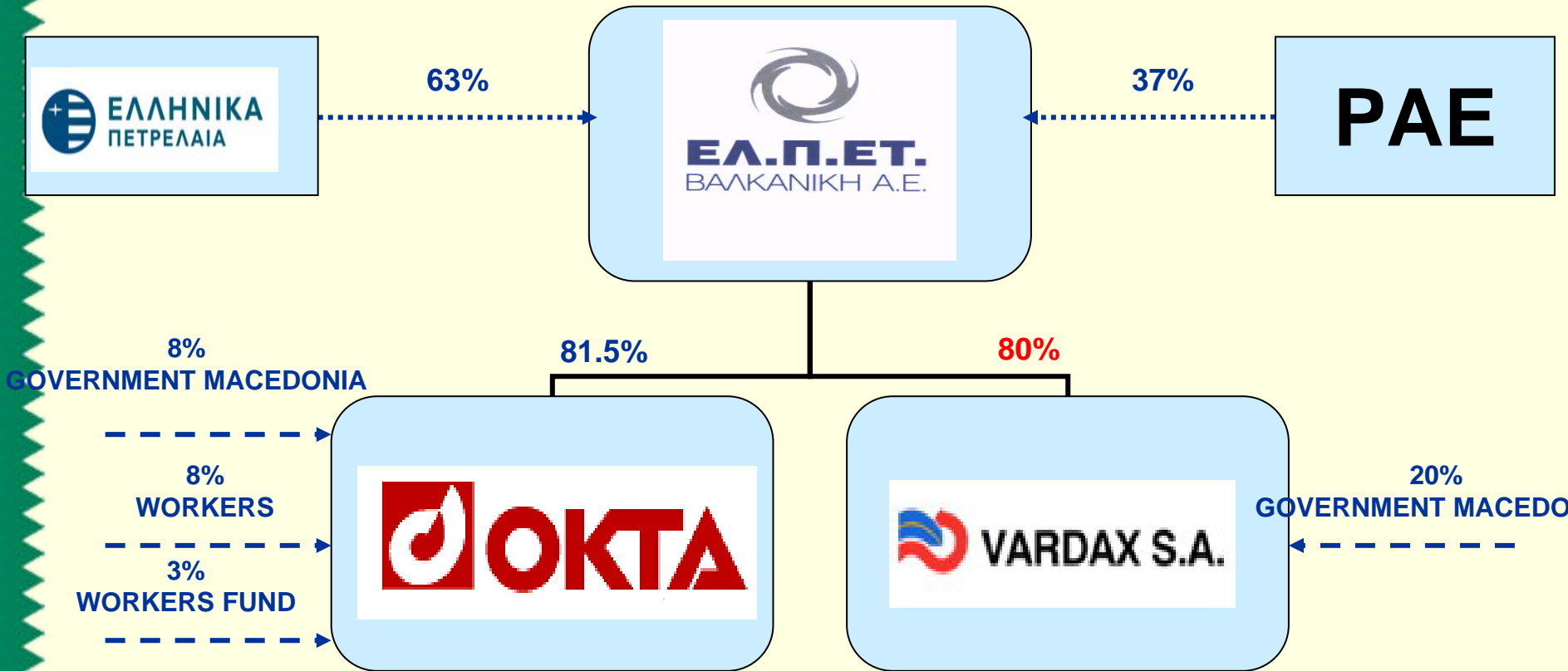

POSITION AND MARKET OF OKTA REFINERY

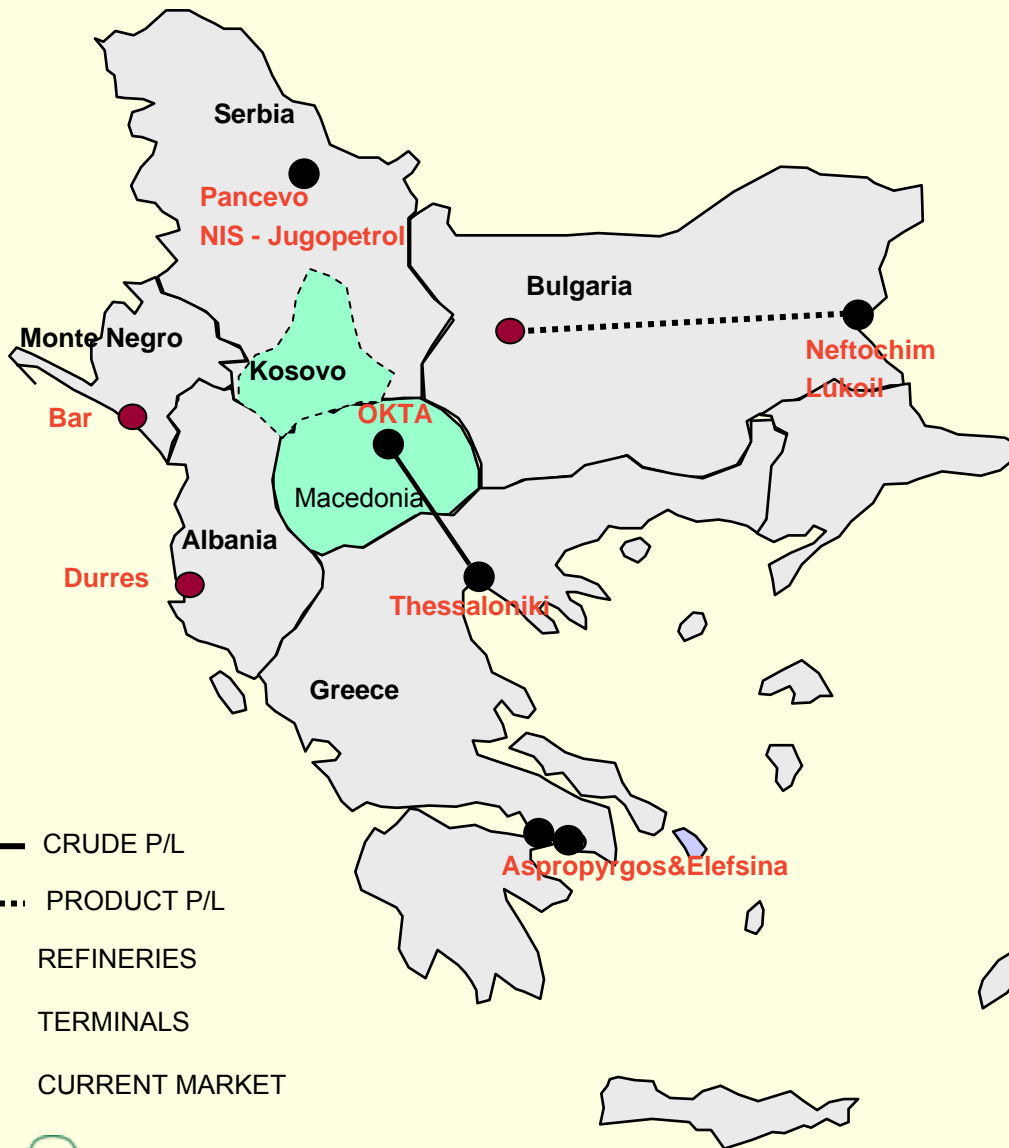

CRUDE PIPELINE VARDAX

- LENGTH : ~230 KM
- CAPACITY : 2.5 MILLION TONS/YR

CURRENT MARKET

- DOMESTIC
- KOSOVO

POSSIBLE ADDITIONAL MARKETS

- SOUTH SERBIA
- WEST BULGARIA
- ALBANIA



REFINERY NOWDAYS PROCESS FLOW DIAGRAM

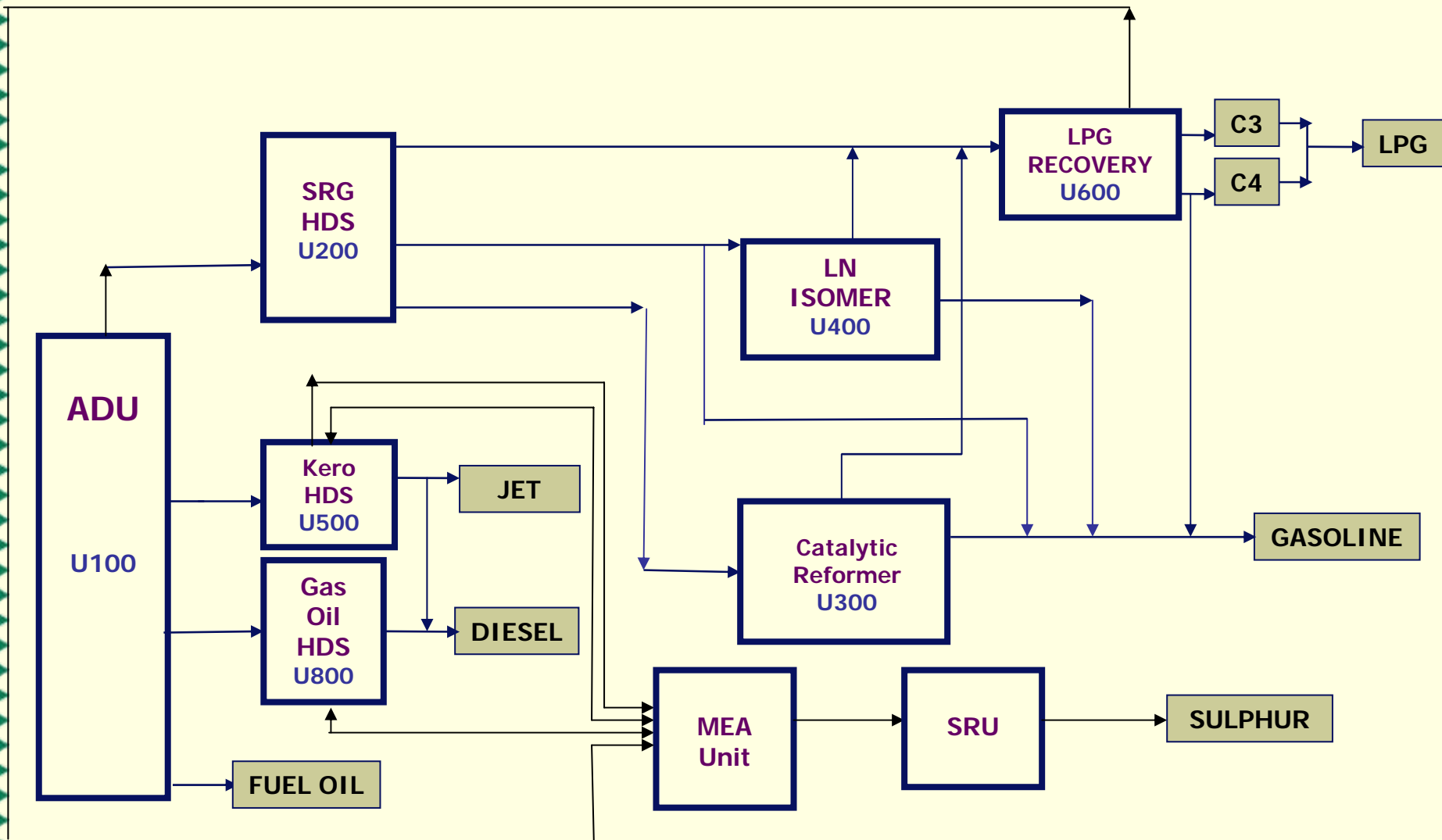

PROCESS UNITS DESIGN CAPACITY

	T/day	kBPSD
Atmospheric Distillation – Crude Unit (U100)	7500	57
HDS of SRG (U200)	1900	16.5
Catalytic Reforming (U300)	1400	12
Light Naphtha Isomerisation (U400)	400	3.9
HDS of Kerosene (U500)	650	5.2
Gas Recovery – LPG Production (U600)	214	2.5
Gasoil HDS (U800)	1200	8.0
SRU (U1000)	12	



OKTA REFINERY COMMERCIAL PRODUCTS

1. Gasoline

- a) Unleaded motor gasoline with 95 RON – Euro V;
- b) Unleaded motor gasoline with 98 RON – Euro V;
- c) Leaded motor gasoline with 96 RON and 0,15 g/l Lead;

2. Diesel Fuels

- a) Diesel Fuel with 50 ppm sulfur - Euro IV;
- b) Diesel Fuel with 10 ppm sulfur - Euro V;

3. JET Fuel – JET A-1 –

4. Heating Fuels –

- a) Heavy Fuel Oil with max 2 %m/m sulphur content;
- b) Heavy Fuel Oil with max 3 %m/m sulphur content;

5. Heating Oil – Extra Light - EL with 1000 ppm sulfur;

6. Liquefied Petroleum Gas – LPG

- a) LPG propane-butane mixture;
- b) LPG Automotive Fuel;
- c) LPG Commercial butane



INVESTEMENTS IN OKTA – part 1

- 1) DCS (Distributed Control System) for all old Units started in 2000, finished in 2008;
- 2) Crude pipeline Thessaloniki-Okta is in operation from 2002. OKTA is transformed from a Continental to a Coastal Refinery;
- 3) Laboratory Upgrading started from 2002 and it's continuing permanently;
- 4) Replacement of all old Russian catalyst with newest generation modern West catalyst in period 2003-2005;
- 5) New Gasoil HDS Unit started with operation from 2004. OKTA started production of Diesel with EU normative quality;
- 6) In period 2003-2006 various projects for Energy conservation (new insulation for HFO storage tanks, new Boilers) and Fire Fighting facilities upgrading were realized;
- 7) In 2006 OKTA Laboratory was granted accreditation by the State Accreditation Institute and became First Accredited Laboratory in Macedonia;
- 8) In 2006, according to the State Law on Environment and Sub legislation and within the framework of the EU directive on Integrated Pollution Prevention and Control, IPPC 1996/61/EC, OKTA submitted Application for A-Adjustment permit with an Adjustment Plan in December 2006 to the Ministry of Environment and Physical Planning,



INVESTMENTS IN OKTA – part 2

- 9) In 2006, a station for Monitoring of ambient air quality SO₂ concentration and smoke in ambient air according EU standards and Rulebook for criteria, methods and procedures for evaluating of ambient air quality, was installed
- 10) In July 2007, Stationary Continuous Monitoring system for monitoring of emission of pollutants in flue gases from Process stack and continuous – once per week monitoring of emission of pollutants in flue gases from Power Plant stack, were installed;
- 11) Replacement of Hydrant Network and Process Units drainage system has been started in 2005 and 2006 and they are in progress;
- 12) In 2006 Retail network of OKTA started with expansion and today it consists of 26 petrol stations, from which 4 are C.O.C.O's Petrol stations and 22 are rebranded (operating under OKTA trademark). OKTA petrol stations are modern facilities designed to offer the wide range of services
- 13) Revamp of Crude Furnaces was performed in period 2006-2007;
- 14) New Sulphur Recovery Unit (SRU) started with operation in 2008. It's unprofitable unit dedicated for protection of the Environmental (clean ambient air and notable improvement of the living conditions of the population)
- 15) Reconstruction of Isomerisation Unit is in final engineering design phase and implementation will be done in 2009;



FUEL QUALITY ACCORDING THE RULEBOOK FOR THE QUALITY OF LIQUID FUELS – HISTORY OF CHANGES

Table 1			1986	2004	2006	2007	2008	2009
Gasoline Lead	g/lit	max	0.02	0.013	0.005	0.005	0.005	0.005
Gasoline Sulphur	ppmw	max	2000	500	500	50	10	10
Gasoline Benzene	% v/v	max	-	5	5	5	5	5/1
Gasoline Aromatics	% v/v	max	-	-	-	45/42	42	42/35
Diesel - Sulphur	ppmw	max	5000/10000	2000	2000 /350	350/50	50/10	50/10
HO Sulphur	ppmw	max	10000	3000	3000	3000	1000	1000
HFO Sulphur	%mas	max	2.0/3.0/4.0	1.0/2.0/3.0	2.0/3.0	2.0/3.0	2.0/3.0	1.0



FUEL QUALITY ACCORDING THE RULEBOOK FOR THE QUALITY OF LIQUID FUELS – OKTA POSSIBILITIES – part 1

- In period of 6 years 2003÷2006, improving of Fuels quality was performed in following ratio:
 - ✓ Sulphur in Diesel – from 5000(10000) to 10 ppm (500(1000) times decreasing);
 - ✓ Sulphur in Gasoline – from 2000 to 10 ppm (200 times decreasing);
 - ✓ Sulphur in HO(EL) – from 10000 to 1000 ppm (10 times decreasing);
 - ✓ Lead in unleaded gasoline – from 0,02 to 0,005 g/l (4 times decreasing);
 - ✓ Sulphur in HFO – from 4 to 1%mas (4 times decreasing)
- The process of improving Fuels quality in term of Environmental, as decreasing of content of sulphur, benzene, aromatics and lead, in more reach European countries and USA, last in period of 15 ÷ 20 years because of the huge investments needed for New technological processes;



FUEL QUALITY ACCORDING THE RULEBOOK FOR THE QUALITY OF LIQUID FUELS – OKTA POSSIBILITIES – part 2

- DIESEL FUEL – Euro V (10 ppm sulphur) MKS EN 590 is reached;
- UNLEADED GASOLINE – Euro V (10 ppm sulphur) MKS EN 228 is reached except Benzene and Aromatics content that will be reached after reconstruction of Isomerisation Unit which is in progress, July 01st 2009;
- HEATING OIL – EU standard of 1000 ppm sulphur is reached;
- HEAVY FUEL OIL – 1% mas Sulphur can be reached only with processing of special high-price low sulphur crude types which are limited on the market. A lot of modifications/investments has to be done with logistic with different crude types at Thessaloniki port, which will increase the final cost of HFO.



OKTA PRODUCTS QUALITY CONTROL

Quality control of OKTA products is performing on several phases:

1. Quality control of each component needed for products blending at process units – at the exit of processes;
2. Quality control of each component in intermediate storage tanks – before blending;
3. Quality control of Blended Product in Final storage tanks – Certificate issuing;
4. Quality control in Final Storage Tanks – after Certificate issuing – scheduled
5. Quality control of OKTA products at OKTA Retail petrol stations – Monitoring schedule control



OKTA LABORATORY ACCREDITATION

- OKTA Laboratory is the First Accredited Laboratory in Macedonia according MKS EN ISO 17025 from May 2006. Since then the confirmation of the OKTA Laboratory's competence is performed by IARM every year. 46 Laboratory test-methods have been accredited;
- OKTA Laboratory is with almost 30 years of experience, and The Laboratory is outfitted with a modern equipment and analysis are carried out according to the newest, world's well-known methods as ASTM, IP, ISO and EN. The staff in the laboratory includes about 40 skilled and experienced employees, and 11 of them are engineers.
- OKTA Laboratory regularly participates in interlaboratory comparisons that are organized and conducted by the Institute for Interlaboratory Studies, Spijkenisse, the Netherlands.
- AIR BP (British Petrol) after performed audit is accepting OKTA Laboratory Quality Certificates for JET Fuel.

